

HV DC Contactor

SEV150AH HV DC Contactor

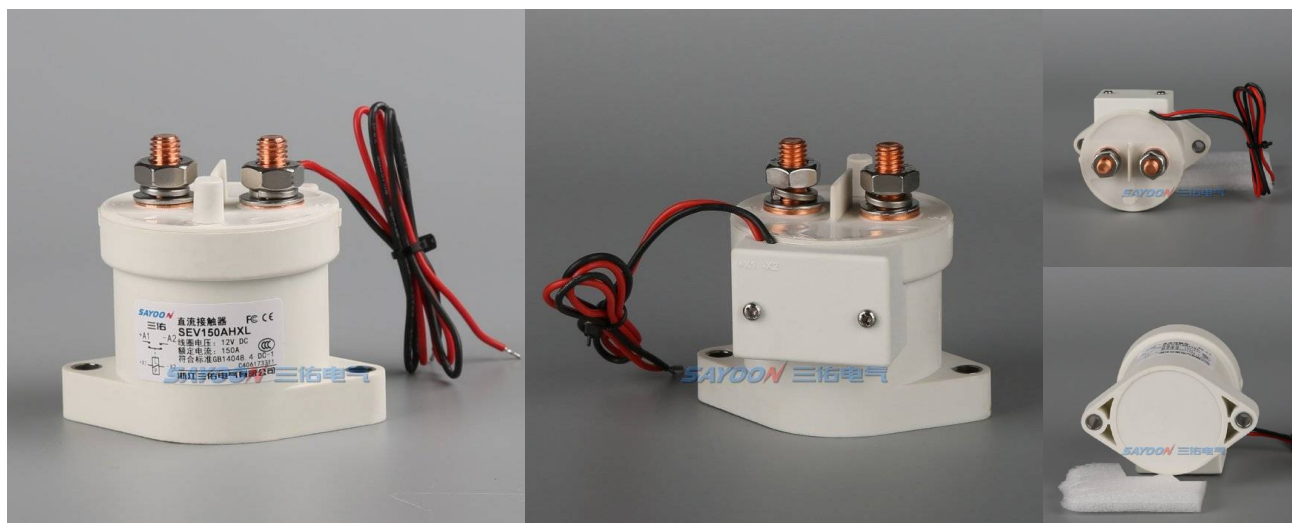

USES

The utility model has the advantages that the utility model is provided with one normally open contact, which is suitable for charging piles, electric four wheeled vehicles, new energy vehicles, energy saving and environmental protection systems, road traffic lighting systems, programmable power supply and uninterruptible power supply equipment.

| SEV | 150 | A | H | X | L | -□ | ※ | /12V |
|-----|--|---|---|---|---|----|---|------|
| 1 | 2 | 3 | 4 | 5 | 6 | 7 | 8 | 9 |
| 1 | Product type | | | | | | | |
| 2 | Rated current | | | | | | | |
| 3 | Circuit structure: A - normally open; B - normally closed; F - normally open with one auxiliary switch (the auxiliary switch and main contact have the same structure); G - one normally closed with one auxiliary (auxiliary switch and main contact have the same structure). (For other auxiliary switch structures, add 2 or 3 numbers after the model to describe the auxiliary switch structure) | | | | | | | |
| 4 | Coil type: D single coil; H with coil economizer; K Two joint magnetic retention(Single coil, Two joint self-locking); 2K Three joint magnetic retention(Double coil, Three joint self-locking); P Signal control | | | | | | | |
| 5 | Coil outgoing mode: X Wire (390mm); P Spade terminals (4.8); W thread(M4); O Other | | | | | | | |
| 6 | Mounting bracket type: L Vertical(default) | | | | | | | |
| 7 | None: auxiliary switch and main contact have the same structure (default); 2: The structure of auxiliary switch and main contact is opposite; 3: Special auxiliary switch structure | | | | | | | |
| 8 | Other special functions: V with capacitive type load; N no polarity | | | | | | | |
| 9 | Coil rated voltage: 12-24V,36-48V,60-72V,9-36V etc. | | | | | | | |

USE OF THE ENVIRONMENT

| | |
|------------------------------|------------------------------------|
| Contact lead M8 tightening | ≥9.0 appropriate |
| Coil lead mode | Wire dipping tin (red positive and |
| Ambient temperature | -40~+85℃ |
| Relative humidity | +20℃ 98% |
| Vibration freq. at the fixed | 3G, 1~50Hz amplitude 0.5mm |
| Concussion | (60~100) time/minute、 |
| Altitude | 2000m |
| Installation direction | Random |
| International Protection | IP68 |

ORDER INSTRUCTION

| | |
|-----------------------|---------------------|
| U.N.W. | 409g |
| Package QTY. | 40PCS |
| Mounting bracket type | L Vertical(default) |

TECHNICAL PARAMETERS

(Version 3.04)

| SAYOON Product Type | SEV150AH |
|---|---------------------------------|
| Contact form | 1 NO(SPST-NO) or 1NC(SPST-NC) |
| Coil Rated voltage (DC V) | 12-24V,36-48V,60-72V,9-36V etc. |
| Contact voltage (DC V) | 5-1000V |
| Contact circuit rated load current (DC-1) | 150A |
| Typical voltage drop across contacts per 100A | ≧80mV |
| The cooling pull-in voltage at (20±5)°C (V) | ≧70% |
| The cooling drop-out voltage at (20±5)°C (V) | ≧35%, ≦5% |
| Working voltage range of 40°C coil | 0.8-1.2Us |
| Drop-out time (n/o contacts to open) | 50ms |
| Pull-in time (n/o contacts to close) | 20ms |
| Maximum bounce time for contact connection | 10ms |
| Maximum bounce time for contact disconnection | 7ms |
| Insulation Resistance | 100MΩ |
| Electric strength to resist | 50Hz/60Hz 2200VAC 1minute |
| Typical fault currents which can be ruptured | 1000A/5ms at 48V DC |
| Coil power (W) | H: Start30-50,Keep1.5-5 |
| Temperature rise of coil (K) | ≤45 |
| Temperature rise on outgoing terminal (K) | ≤65 |
| Electrical life | 20,000 times |
| Mechanical life | 300,000 times |
| Work specification | Continuous |
| Contact material | Alloy |
| Inrush time (max) | 130ms |
| Maximum switching current | 2000A 320VDC (more than once) |
| Maximum switching power | 640kW |
| Load terminal type | M8 Screw |

LOAD CHARACTERISTIC CURVE

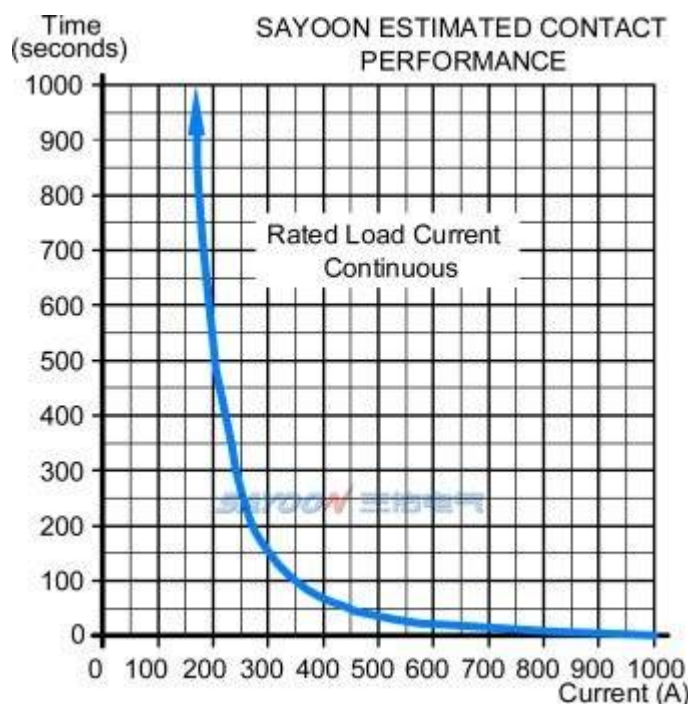
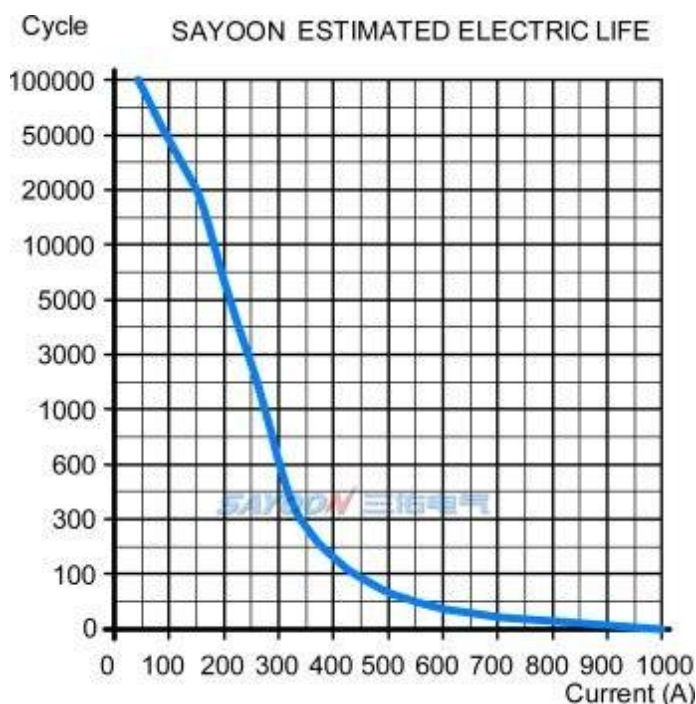

OTHER TECHNICAL PARAMETERS

| | |
|---|--------------------------------------|
| Coil terminal type | 0.3 square silicone wire, 390mm long |
| Auxiliary contact rated load (optional) | 3A/30VDC |
| Testing organization certification | CCC,CE,FCC,RoHS |

Note:As regarding to the different using environments of customers which requires different focus of the functions,and in order to improve the comprehensive properties of our products,sayoon may adjust the coil parameters,temperature rise and so on. The above parameters are for reference only, For details, please refer to the guidelines for selection and use of the SAYOON DC contactor.

INSTALLATION DIAGRAM

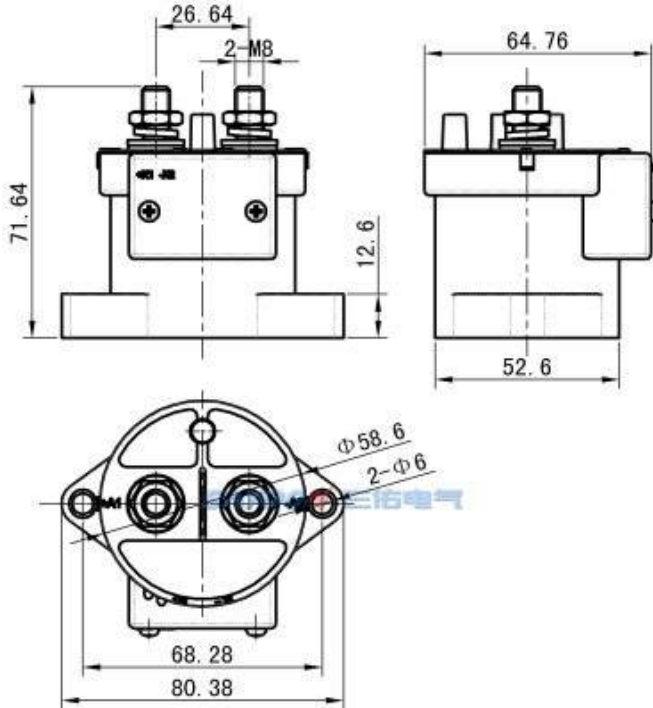

WIRING DIAGRAM

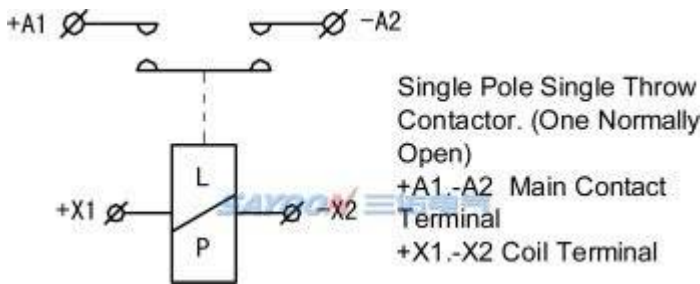

TEMPERATURE RISE CURVE

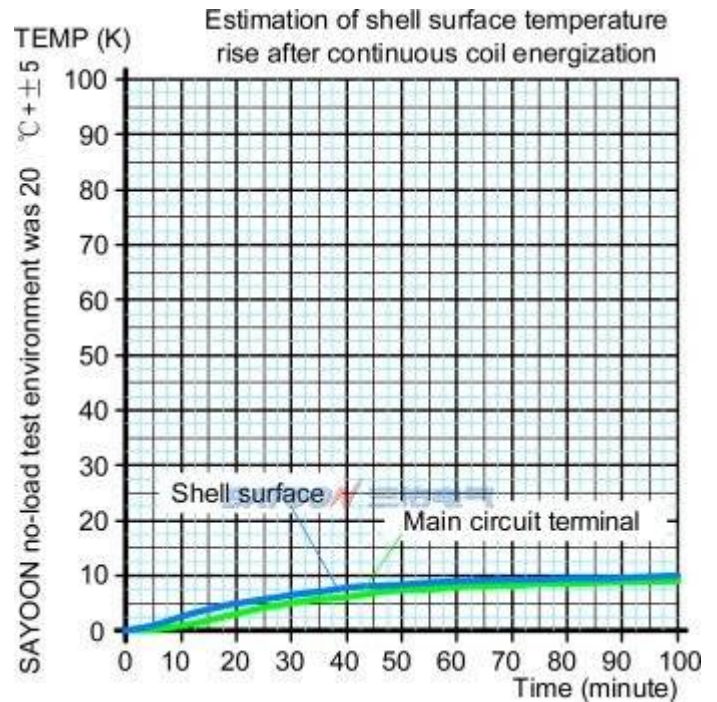

FEATURES

Suitable for new energy electric vehicles, charging facilities, photovoltaic, wind power generation systems, automotive air conditioning, communication power, UPS, power and other electrical control circuit of the switch control, with small size, large load capacity, no spark, long service life, maintenance simple and other characteristics, by users. 1 DC high voltage power: the product cavity filled with rare mixed gas, arc cooling capacity, 2 control load capacity: with 30A-1000A, working voltage range of 5-1000VDC load capacity; 3 safety: insulation structure, can be in flammable or hazardous environment work, coil and contacts will not oxidation and pollution; 4, compared with similar products small size, light weight, power consumption. The product in accordance with the standard JB2286-78, JB3974-85, YD / 585-92, YD / T512-92 requirements; after the factory and relevant test unit test, meet the requirements of the standard specification, users use for many years, maximum to meet user needs, quality and reliable.

ORDER FORM DESCRIPTION

When ordering, please state the following: name, full model, control coil voltage specification, installation frame type, whether with auxiliary contact, order quantity. For example: HV DC Contactor SEV200AH-□-□/24V 100pcs, indicating the load rated current 200A, without auxiliary contact, default mounting bracket, coil control voltage 24V purchase 100pcs. Special voltage specification products, such as user needs can be special order.